

LiquaVision® Set-Up Manual for the Make-Up Models

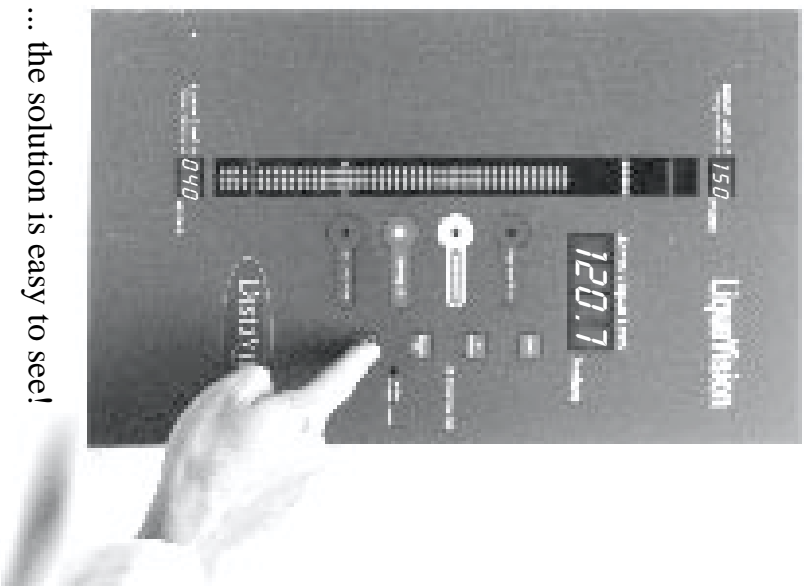

... the solution is easy to see!



Distaview Corporation

(419) 354-5087

Fax (419) 353-6080

<http://www.Distaview.com>

e-mail: sales@distaview.com

©Distaview® Corp., Specifications are subject to change without notice. Printed in U.S.A.

DV604M 3/18/02

LiquaVision® Features and Overview

LiquaVision® is a solid-state controller with a variety of unique control and display features. It's designed to simply present the crucial information, at a glance. It's built to perform in all types of harsh industrial environments.

Topics covered in this manual:

- Displaying Your Tank's Cross-Section
- Security Levels / Select and Enter Data
- Initial Set-Up / Eight Simple Steps
- Sensor Connections / Schematics
- Sending a 4-20 mA Signal to Other Devices
- Other Helpful Features of LiquaVision®

Let's say your tank is 112 inches deep, and the transducer range of the sensor you've chosen is 0-5 psi of water. 5 psi equals 138 inches H2O. The pressure transducer is located 11 inches off the bottom of the tank. With 51 inches of water in the tank you are cavitating the pump, and at 108 inches of water you are facing probable flooding.

The goal is to maintain the liquid level between 90 and 65 inches using LiquaVision®. The following steps should be taken in order to display a 50 to 110 inch "window" on the tank, while maintaining a liquid level range of 90 to 65 inches. High and low alarm output circuits will be activated at 105 and 55 inches.

The Initial Set-up in Eight Easy Steps (see page 4) describes in detail how to program LiquaVision® for your specific application. To accomplish the above installation, you would enter the following:

Transducer Range	138.0 inches H2O
Transducer Height	11.0
Upper Limit of Window	110.0
Lower Limit of Window	50.0
High Alarm/Fault Level	105.0
Make-up OFF Level	90.0
Make-up ON Level	65.0
Low Alarm/Fault Level	55.0

Tank Cross-Section Display with LiquaVision®

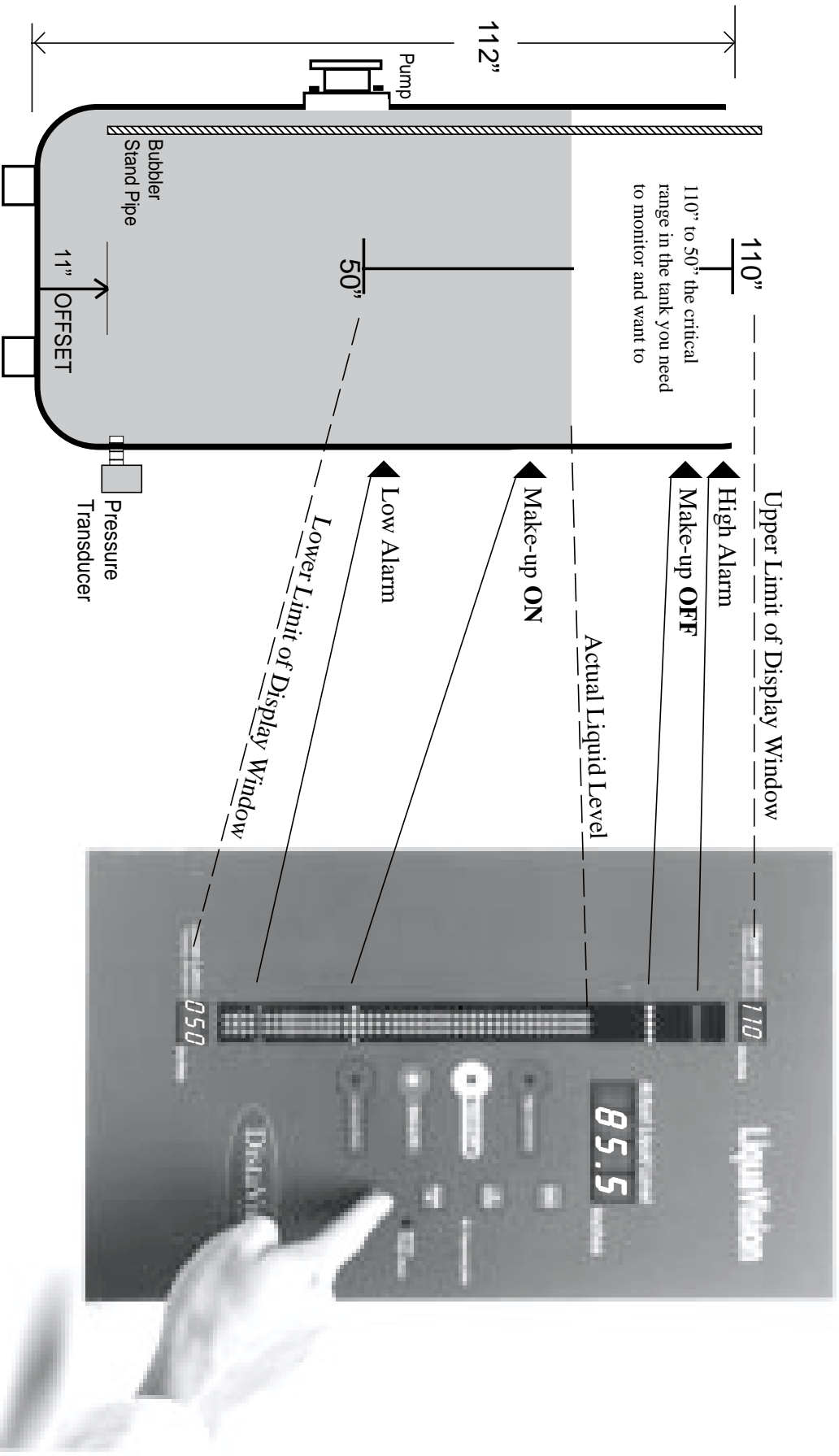

Security Levels / Selecting and Accessing Data

Operator access to data modifications has three modes of security: View Only, Set Point Changes Allowed and Programming. Each mode is selected from the back of the unit with a DIP switch setting.

Programming Mode

This mode, #1 ON, allows you to change all eight programmable settings. It is used for initial set-up and installation.

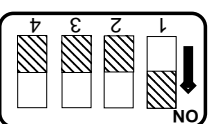

Set Point Changes Allowed

This mode, #2 ON, allows you to change all four set points: the High & Low Alarms, Make-up ON & Make-up OFF.

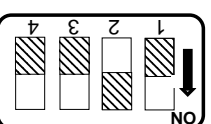

View Only Mode

This mode, ALL OFF, prevents any changes from being made. However, all the information, except the transducer range and transducer offset, is available by pressing SELECT.

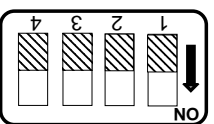

Output & Input Terminal Connections

(All terminal connections are Phoenix type)

Output Terminals

12. High Level N.C.	10.0 amp
11. High Level Com	10.0 amp
10. High Level N.O.	10.0 amp
9. Make-up ON N.C.	10.0 amp
8. Make-up ON Com	10.0 amp
7. Make-up ON N.O.	10.0 amp
6. Low Level N.C.	10.0 amp
5. Low Level Com	10.0 amp
4. Low Level N.O.	10.0 amp
3. Make-up ON N.C.	10.0 amp
2. Make-up ON Com	10.0 amp
1. Make-up ON N.O.	10.0 amp

#1-#3 Make-up range operates at same level as #7-#9. Consider it a spare Form C make-up relay.

120 VAC Power Supply

3. 120 VAC - Com.
2. Ground
1. 120 VAC - Hot

Sensor Input

4. 4-20 mA (-)
3. 4-20 mA (+)
2. Ground
1. + 24 VDC Output

NOTE: Terminal #1 provides power for loop powered sensors.



24 Volt DC Power Supply (Unregulated)

3. 24 VDC - Neg (-)
2. Ground
1. 24 VDC - Pos (+)

Initial Set-Up in Eight Easy Steps

The initial set-up requires you to change the DIP switch to Programming Mode, #1 ON. After the initial set-up, select the DIP switch settings for View Mode or Set Point Changes Allowed. (More detail on Page 3.) Holding down the INCREASE or DECREASE arrow for 3 seconds increases the scrolling speed of the numbers on the display.

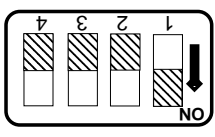

1. - Setting the Transducer Range Press the **SELECT** button on the graphic face - **RANG** will appear in the display. A few seconds later, the display will convert to **R _ _ _**. The Transducer Range of the input device needs to be entered, using the INCREASE or DECREASE arrow. The Transducer Range is determined by the manufacturer of the device. It is printed on the device, typically in either psi, inches of water or inches mercury. It is not the height of the tank you are controlling. *For example:* if you want to display a 120" tank of water in inches and have a transducer that has a manufacturer's range of 0-5 psi, you would use the following formula:

$$\frac{(5.0 \text{ psi water}) (27.7 \text{ inches})}{1.0 \text{ specific gravity of water}} = 138.5 \text{ inches} \quad (\text{Note: 1psi water} = 27.7")$$

2. - Setting Offset / Transducer Height Press the **SELECT** button again and **OFST** will appear in the display. A few seconds later, the display will convert to **L _ _ _**. Enter the Transducer Height by pressing the INCREASE or DECREASE arrow. Transducer Height is the location of the transducer from the bottom of the tank, or if you are using a bubbler it is to the bottom of the bubbler stand pipe.

3. - Selecting the Upper Cross-Section Press the **SELECT** button again - the **Upper Limit** small numeric window display will begin to flash and the main display will convert to **P _ _ _**. The Upper Limit display level needs to be entered, using the INCREASE or DECREASE arrow. This is the "window" or cross-section of the tank you want to see displayed on the vertical bar display. It is not a control or alarm level.

This is one of the unique features of LiquaVision®. You can select to display any portion of the height of your tank. *For example:* Suppose you have a 120" tall tank that you want to control. Filters and pumps occupy the bottom 50 inches, and you don't want the level to ever go above 105". At the same time, you want to display the crucial operating range of your tank, including make-up levels, high/low alarms and the actual level. To select the highest resolution of this crucial range on the bar display, you would enter the **Upper Limit P _ _ _** at 110" and the **Lower Limit P _ _ _** at 50". You can select to display any cross-section you require for the installation.

4. - Selecting the Lower Cross-Section Press the **SELECT** button again - the **Lower Limit** small numeric window display will begin to flash and the main display will convert to **P _ _ _**. The **Lower Limit** display level needs to be entered, using the **INCREASE** or **DECREASE** arrow. This is the window or cross-section of the tank you want to see on the bar graph display. It is **not** a control or alarm level. (See the above *For example.*)

NOTE: The previous four steps are protected from data changes when you choose either one of the other security modes. The next four steps are accessible to changes in either the **Programming Mode** (at the initial set-up) or with **Set Point Changes Allowed** mode selected.

5. - Entering the High Alarm Level Press the **SELECT** button again - the **High Level Alarm Point** indicator LED on the graphic face and the top **RED** line in the bar graph display will flash. **P _ _ _** appears in the display. Enter the level, using the **INCREASE** or **DECREASE** arrow to set the desired level. When this point or level is reached, it will indicate a High Level Alarm has been reached and activate the control circuit/device you have designed into your system.

6. - Entering the Make-Up Off Level Press the **SELECT** button again - the yellow **Make-Up OFF** indicator LED will flash along with the **YELLOW** line in the bar graph. **P _ _ _** appears in the display. Enter the level, using the **INCREASE** or **DECREASE** arrow to set the desired Make-Up Off level. When this point or level is

reached, LiquaVision® will deactivate the differential output(s) to the control circuit/device you have designed into your system. **NOTE:** The Make-Up differential has a Form-C **and** TRIAC circuit operating simultaneously. You can use both or either in your design.

7. - Entering the Make-Up ON Level Press the **SELECT** button again - the **Make-Up ON** indicator LED and the **ORANGE** line in the bar graph will flash. **P _ _ _** appears in the display. Enter the Make-Up ON level, using the **INCREASE** or **DECREASE** arrows. When this point or level is reached, LiquaVision® will activate the differential output(s) to the control circuit/device you have designed into your system. **NOTE:** The Make-Up differential has a Form-C **and** TRIAC circuit operating simultaneously. You can use both or either in your design.

8. - Entering the Low Alarm Level Press the **SELECT** button again - the **Low Level Alarm Point** indicator LED on the graphic face and the top **RED** line in the bar graph display will flash. **P _ _ _** appears in the display. Enter the Low Alarm Level, using the **INCREASE** or **DECREASE** arrow. When this point or level is reached, it will indicate a Low Level Alarm has been reached and activate the control circuit/device you have designed into your system.

Sensor Input Connections / Schematics

Signal Power Supplied by LiquaVision (Loop Powered)

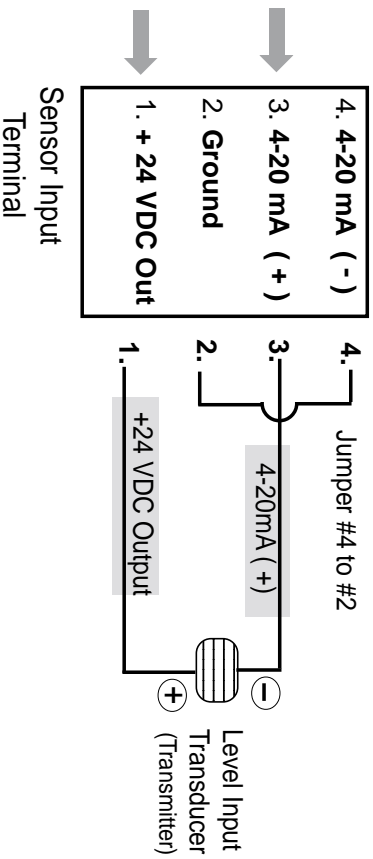

Typical Form-C Relay Connection

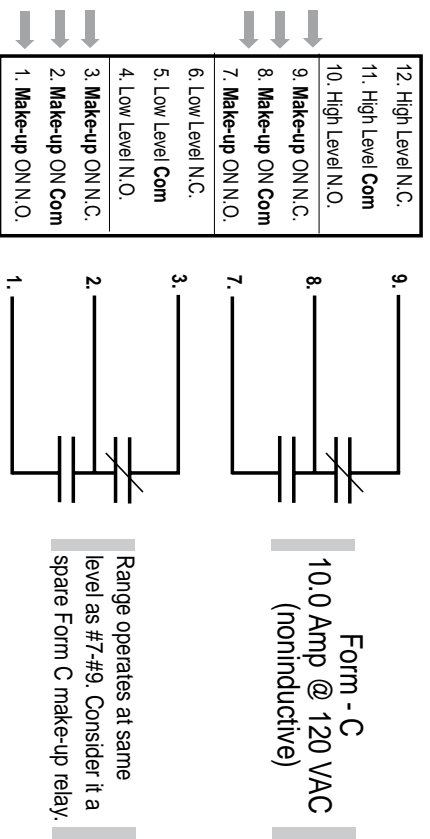

Signal Power Supplied by Other Source

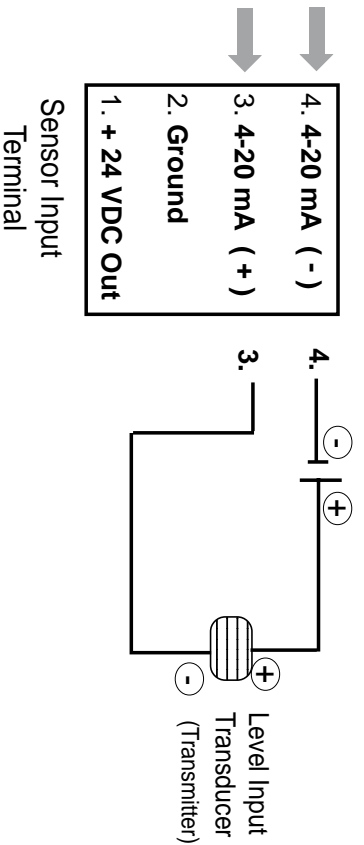

Sending 4-20ma Signal to Other Devices

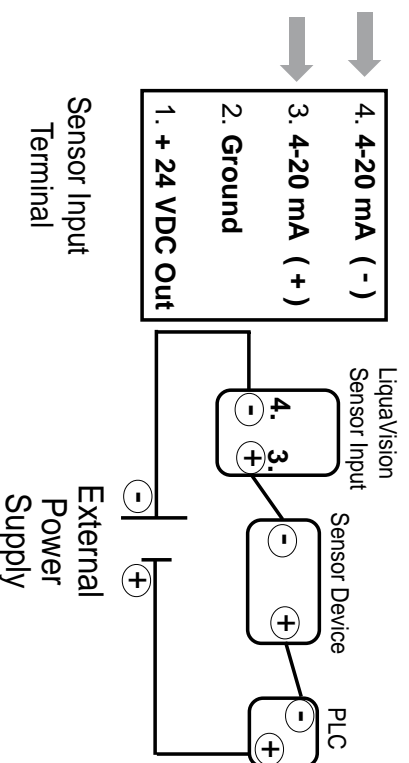

Other Helpful Features of LiquaVision®

Interrupted 4-20 mA Signal from Sensor

Whenever the 4-20 mA signal from the sensor device is lost because of an open wire or device malfunction, an **ERR3** message is displayed in the Actual Liquid Level window. Additionally, the entire bar display will flash red and green.

Over &/or Under 4-20 mA signal received

When the input sensor is sending a 4.0 mA signal, the Actual Liquid Level display will show a V character in the first digit of the display.

Actual Liquid Level
 V00.0

Process Signal
Input is 4.0 mA, but
not an open wire.

See above for open wire

Actual Liquid Level
 A00.0

Process Signal
Input is 20.0 mA

Software Version Numbers

The version number of your LiquaVision® unit is shown in the Actual Liquid Level display window when you power up the unit. If your unit has version 1.7, you will see in the window **LV 1.7**

Programmed data cannot be lost

All the data and logic are written to a permanent EEPROM, which will retain your data in the event the power supply is disconnected. There is no battery on the board to maintain the data in the EEPROM.

Additional Models of LiquaVision®

Four Point

This version has **4 discrete control points**, rather than one differential and two alarm points, as in LiquaVision®.

Two View®

Dual pump controller with **high and low alarm** circuits. Patented control features include two differential lead and lag ranges, allowing you to alternate the pumps or designate a primary pump.