



# LiquaVision<sup>®</sup>

## Set-Up Manual

for the  
Sump Model  
Serial Numbers 3000+



DistaView Corp.  
(419) 354-5087  
Fax (419) 353-6080  
<http://www.Distaview.com>  
e-mail: [distaview@wcnet.org](mailto:distaview@wcnet.org)

## **LiquaVision® Features and Overview**

LiquaVision® is a solid-state controller with a variety of unique control and display features. It's designed to simply present the crucial information at a glance. It's built to perform in all types of harsh industrial environments.

### **Topics covered in this manual:**

- Displaying Your Tank's Cross-Section
- Security Levels / Select and Enter Data
- Initial Set-Up / Eight Simple Steps
- Sensor Connections / Schematics
- Sending a 4-20 mA Signal to Other Devices
- Other Helpful Features in LiquaVision®
- Determine the Model Number for You

**L**et's say your tank is 112 inches deep, and the transducer range of the sensor you've chosen is 0-5 psi of water. 5 psi equals 138 inches H<sub>2</sub>O. The pressure transducer is located 11 inches off the bottom of the tank. With 51 inches of water in the tank, you are cavitating the pump and at 108 inches of water you are facing probable flooding.

The goal is to maintain the liquid level between 90 and 65 inches using LiquaVision®. The following steps should be taken in order to display a 50 to 110 inch "window" on the tank while maintaining a liquid level range of 90 to 65 inches. High and low alarm output circuits will be activated at 105 and 55 inches.

The **Initial Set-up in Eight Easy Steps** (see page 4) describes in detail how to program LiquaVision® for your specific installation. To accomplish the above installation you would enter the following:

Transducer Range	138.0 inches H <sub>2</sub> O
Transducer Height	11.0
Upper Limit of Window	110.0
Lower Limit of Window	50.0
High Alarm/Fault Level	105.0
Sump On Level	90.0
Sump Off Level	65.0
Low Alarm/Fault Level	55.0

## Tank Cross-Section Display with LiquaVision®

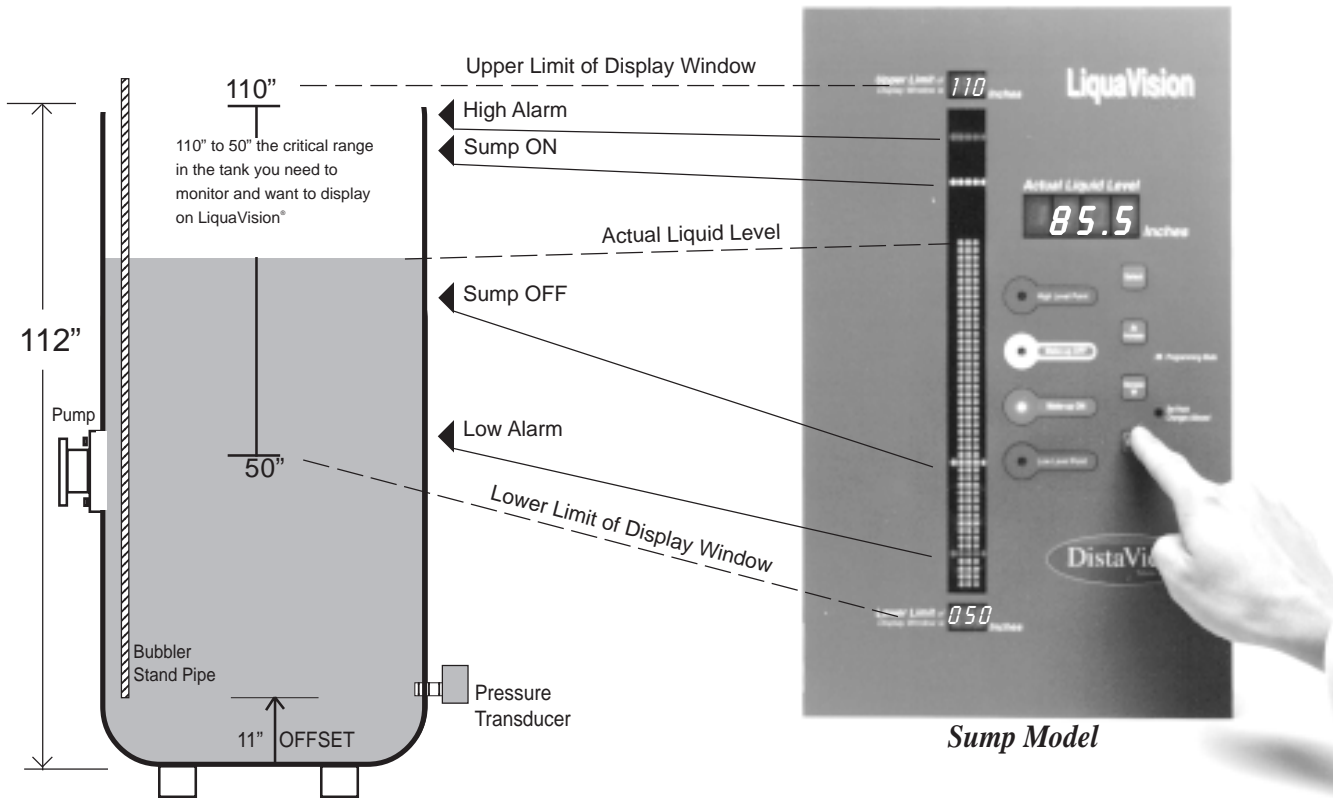

## Security Levels / Selecting and Accessing Data

Operator access to data modifications has three modes of security: View Only, Set Point Changes Allowed and Programming. Each mode is selected from the back of the unit with a DIP switch setting.

### Programming Mode

This mode, #1 ON, allows you to change all eight programmable settings. It is used for initial set-up and installation.

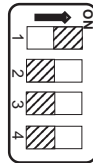

### Set Point Changes Allowed

This mode, #2 ON, allows you to change all four set points: the High & Low Alarms, Sump OFF & Sump ON.

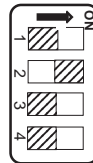

### View Only Mode

This mode, ALL OFF, prevents any changes from being made. However, all the information, except the transducer range and transducer offset, is available by pressing SELECT.

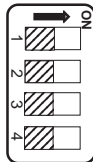

## Output & Input Terminal Connections

(All terminal connections are Phoenix type)

### 120 VAC Power Supply

**Power Supply**  
3. 120 VAC - Com.  
2. Ground  
1. 120 VAC - Hot

### Sensor Input

4. 4-20 mA (-)  
3. 4-20 mA (+)  
2. Ground  
1. + 24 VDC Output

### 24 Volt DC Power Supply (Unregulated)

**Power Supply**  
3. 24 VDC - Neg (-)  
2. Ground  
1. 24 VDC - Pos (+)

Output Terminals	
12.	High Level N.C.
11.	High Level Com
10.	High Level N.O.
9.	Sump ON N.C.
8.	Sump ON Com
7.	Sump ON N.O.
6.	Low Level N.C.
5.	Low Level Com
4.	Low Level N.O.
3.	Sump ON N.C.
2.	Sump ON Com
1.	Sump ON N.O.
#1-#3 Sump range operates at same level as #7-#9. Consider it a spare Form C sump relay.	

**NOTE:** Terminal #1 provides power for loop powered sensors.

## Initial Set-Up in Eight Easy Steps

PROGRAMMING MODE

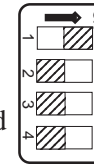

The initial set-up requires you to change the DIP switch to Programming Mode, #1 ON. After the initial set-up, select the DIP switch settings for View Mode or Set Point Changes Allowed. (More detail on Page 3.) Holding down the INCREASE or DECREASE arrow for 3 seconds increases the scrolling speed of the numbers on the display.

**1. - Setting the Transducer Range** Press the **SELECT** button on the graphic face - **RANG** will appear in the display. A few seconds later, the display will convert to **R \_ \_ \_**. The **Transducer Range** of the input device needs to be entered, using the INCREASE or DECREASE arrow. The Transducer Range is determined by the manufacturer of the device. It is printed on the device, typically in either psi, inches of water or inches mercury. It is not the height of the tank you are controlling. *For example:* if you want to display a 120" tank of water in inches and have a transducer that has a manufacturer's range of 0-5 psi, you would use the following formula:

$$\frac{(5.0 \text{ psi water}) (27.7 \text{ inches})}{1.0 \text{ specific gravity of water}} = 138.5 \text{ inches} \quad (\text{Note: 1psi water} = 27.7'')$$

**2. - Setting Offset / Transducer Height** Press the **SELECT** button again and **DFST** will appear in the display. A few seconds later, the display will convert to **L \_ \_ \_**. Enter the **Transducer Height** by pressing the INCREASE or DECREASE arrow. Transducer Height is the location of the transducer from the bottom of the tank, or if you are using a bubbler it is to the bottom of the bubbler stand pipe.

**3. - Selecting the Upper Cross-Section** Press the **SELECT** button again - the **Upper Limit** small numeric window display will begin to flash and the main display will convert to **P \_ \_ \_**. The **Upper Limit** display level needs to be entered, using the INCREASE or DECREASE arrow. This is the "window" or cross-section of the tank you want to see displayed on the vertical bar display. It is **not** a control or alarm level but simply the upper value of the tank being displayed in the vertical bar.

This is one of the unique features of LiquaVision®. You can select to display any portion of the height of your tank. *For example:* Suppose you have a 120" tall tank that you want to control. Filters and pumps occupy the bottom 50 inches, and you don't want the level to ever go above 105". At the same time, you want to display the crucial operating range of your tank, including make-up levels, high/low alarms and the actual level. To select the highest resolution of this crucial range on the bar display, you would enter the **Upper Limit P \_ \_ \_** at 110" and the **Lower Limit P \_ \_ \_** at 50". You can select to display any cross-section you require for the installation.

**4. - Selecting the Lower Cross-Section** Press the **SELECT** button again - the **Lower Limit** small numeric window display will begin to flash and the main display will convert to **P \_ \_ \_**. The **Lower Limit** display level needs to be entered, using the INCREASE or DECREASE arrow. This is the window or cross-section of the tank you want to see on the bar graph display. It is **not** a control or alarm level but simply the lower value of the tank being displayed in the vertical bar.. (See the above *For example.*)

**NOTE:** The previous four steps are protected from data changes when you choose either one of the other security modes. The next four steps are accessible to changes in either the **Programming Mode** (at the initial set-up) or with **Set Point Changes Allowed** mode selected.

**5. - Entering the High Alarm Level** Press the **SELECT** button again - the **High Level Alarm Point** indicator LED on the graphic face and the top RED line in the bar graph display will flash. **P \_ \_ \_** appears in the display. Enter the level, using the INCREASE or DECREASE arrow to set the desired level. When this point or level is reached, it will indicate a High Level Alarm has been reached and activate the control circuit/device you have designed into your system.

**6. - Entering the Sump ON Level** Press the **SELECT** button again - the yellow **Sump ON** indicator LED will flash along with the YELLOW line in the bar graph. **P \_ \_ \_** appears in the display. Enter the level, using the INCREASE or DECREASE arrow to set the desired Sump ON level. When this point or level is reached,

---

LiquaVision® will deactivate the differential output(s) to the control circuit/device you have designed into your system.

**7. - Entering the Sump OFF Level** Press the **SELECT** button again - the **Sump OFF** indicator LED and the **ORANGE** line in the bar graph will flash. **P \_ \_ \_** appears in the display. Enter the Sump OFF level, using the **INCREASE** or **DECREASE** arrows. When this point or level is reached, LiquaVision will activate the differential output(s) to the control circuit/device you have designed into your system.

**8. - Entering the Low Alarm Level** Press the **SELECT** button again - the **Low Level Alarm Point** indicator LED on the graphic face and the top **RED** line in the bar graph display will flash. **P \_ \_ \_** appears in the display. Enter the Low Alarm Level, using the **INCREASE** or **DECREASE** arrow. When this point or level is reached, it will indicate a Low Level Alarm has been reached and activate the control circuit/device you have designed into your system.

## Sensor Input Connections / Schematics

### Signal Power Supplied by LiquaVision® (Loop Powered)

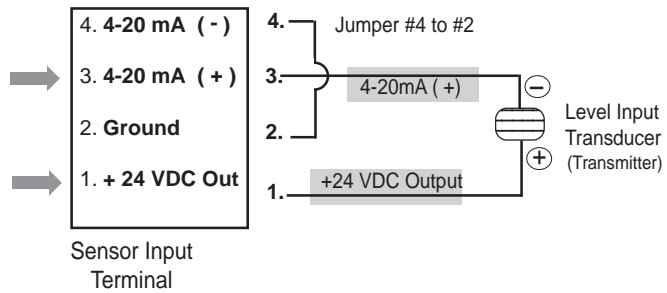

### Typical Form-C Relay Connection

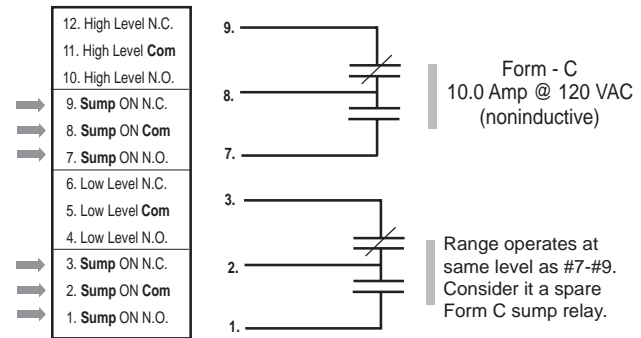

### Signal Power Supplied by Other Source

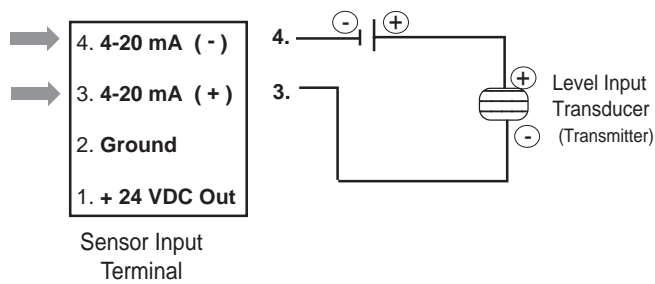

### Sending 4-20 mA Signal to Other Devices

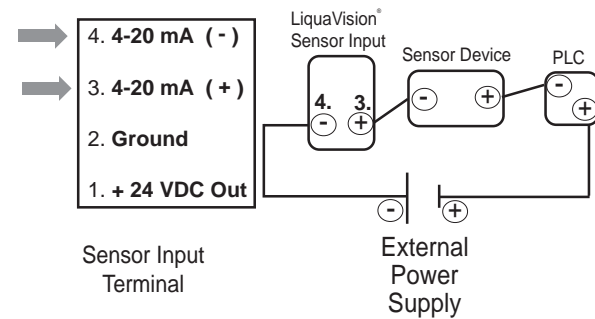

## Other Helpful Features of LiquaVision®

### Interrupted 4-20 mA Signal from Sensor

Whenever the 4-20 mA signal from the sensor device is lost because of an open wire or device malfunction an **ERR 3** message is displayed in the Actual Liquid Level window. Additionally, the entire bar display will flash red and green.

### Over &/or Under 4-20 mA signal received

When the input sensor is sending less than a 4.0 mA signal the Actual Liquid Level display will show a  $\nabla$  character in the first digit of the display.

Actual Liquid Level  

Process Signal  
 Input is 4.0 mA but  
 not an open wire.  
 See above for open wire

Actual Liquid Level  

Process Signal  
 Input is 20.0 mA

## Software Version Numbers

The version number of your LiquaVision® unit is shown in the Actual Liquid Level display window when you power up the unit. If your unit has version 2.8, you will see in the window **LV 2.8**

### Programmed data cannot be lost

All the data and logic are written to an permanent EEPROM that will retain your data in the event the power supply is disconnected. There is no battery on the board to maintain the data in the EEPROM.

## Additional Models of LiquaVision®

### 4-Point

This version has **4 discrete control points** rather than one differential and two alarm points in Make-up or Sump LiquaVision® Models.

## LiquaVision® Part Numbers

Controller Operation	Units of Measurement	Language	Power Supply Voltage
MU Make-Up	01 Inches	E English	024 24 Volt DC
SU Sump	02 Centimeters	S Spanish	120 120 Volt AC
4P Four Point	06 Special Order		220 220 Volt AC
SP Special Order			

 - LQV  
 Control Units Language Power